

Frozen
Frozen granita dispenser with 2 bowls,
mechanical control and lighted panel,
UK Plug and UV light

ITEM # _____

MODEL # _____

NAME # _____

SIS # _____

AIA # _____



562540 (IPRO2MLUVR290) Frozen Granita Dispenser with 2X11 l insulated bowls, UV light, mechanical control and lighted panel, R290 - UK plug

Short Form Specification

Item No. _____

Frozen granita dispenser with 2 bowls; the ITANK™ Technology prevents ice accumulation on the outer side of the bowl and the bowl shape allows a natural mixing action to ensure an optimum consistency of the product. Customizable lid merchandiser and back graphic. Mechanical keypad allows for setting of cooling and defrost modes. Exclusive nUV LED system for bowl sanitation. Front illuminated panel provides customers with the opportunity to advertise their product and maximise impulse buying. Electromechanical control. Sliding drip tray.

Main Features

- Ideal for the production of slush.
- The ITANK™ Technology prevents ice accumulation on the outer side of the bowl, reducing condensation and increasing the cooling power of the machine.
- Bowl shape allows a natural mixing action to ensure an optimum consistency of the product.
- Customizable lid merchandiser and back graphic.
- Ideal for operators who want an innovative and distinctive equipment. Mechanical keypad allows for setting of cooling and defrost modes.
- The front illuminated panel provides customers with the opportunity to advertise their product and maximise impulse buying.
- The insulated tank guarantees higher cooling efficiency and lower effect of the external temperature on product's preparation and maintenance time reducing condense and draining; it is the best solution in hot climate conditions.
- Exclusive nUV LED system for bowl sanitation.

Construction

- Electromechanical control.
- Sliding drip tray.

APPROVAL: _____

Front

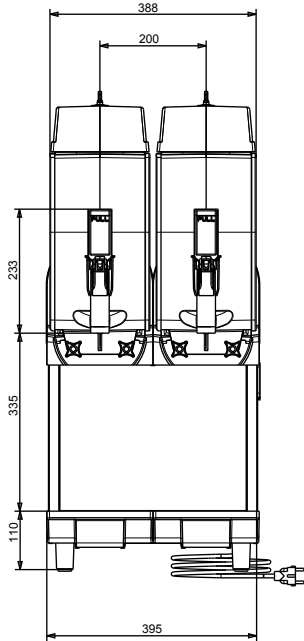

Side

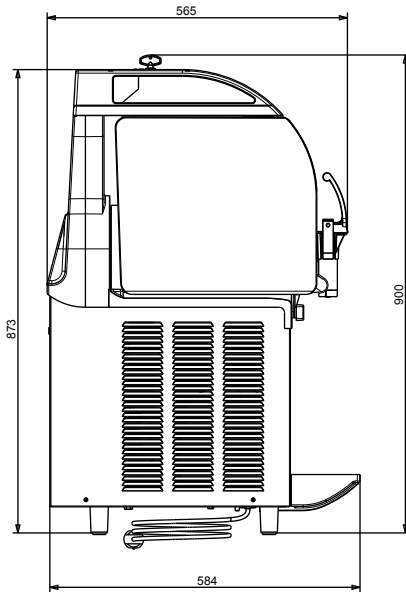

Top

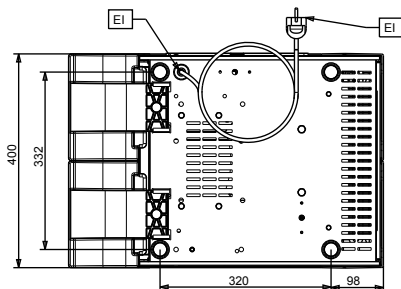

Electric

Supply voltage:

562540 (IPRO2MLUVR290) 220-240 V/1 ph/50 Hz

Electrical power max.:

0.83 kW

Key Information:

External dimensions, Width: 400 mm

External dimensions, Depth: 580 mm

External dimensions, Height: 870 mm

Net weight: 60 kg

Sustainability

Refrigerant type:

R290